

M a r c h 2 0 2 3

CHEVY CHATTER

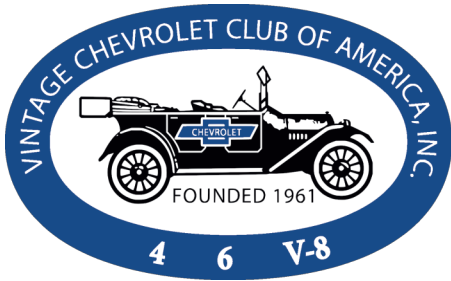

Lower Michigan Region



Help show off our region!

We're getting fired up about the 60th VCCA Central Meet, and looking forward to showing off the Gilmore Car Museum to a whole new group of members! We already have members signed up who are coming from Iowa, Wisconsin, Maine, and elsewhere!

We know that many of you in the LMR have enjoyed the Gilmore's campus and the greater Kalamazoo area, and sometimes more than once. We hope that you will share our enthusiasm for this milestone meet by registering to join the fun, and volunteering however you can. We need folks as greeters at the registration tables, helping with field entrance check, parking cars on the judging field, selling raffle tickets, and more. For those that have already called or emailed that you're willing to help, we will be in touch with you soon to give you an assignment.

We are going to build a basket of Michigan based products to donate to the meet basket raffle, so if you can contribute something from your neighborhood, please email or text that information to the contact information below.

Just a reminder: any information you need to join the meet festivities can be found at

www.vccacentralmeet.org, including hotel reservations (which are open now until June 25), updates on meet registration, and meet schedules. Please, note the website is a work-in-progress as is subject to change. Registration forms will be available April 1st, 2023.

If you have further questions, please do not hesitate to call Pat Mehl at 269-217-1253, or email her at pat.m.vcca@gmail.com. 

Do you have your Hotel for the 60th Central Meet Yet? Now is the time!

Host Hotel: Four Points by Sheraton
3600 E. Cork St.
Kalamzoo, MI 49001
(866) 961-3003
use code: VCC

On This Date in History:

Albert Kahn "The Architect of the Auto Industry" is born
 March 21, 1869 - December 8, 1942

Albert Kahn was born in Rhaunen, Prussia (Present day Germany). He immigrated to the United States with his parents in 1881 at the age of 12. His father was a Jewish Rabbi and his mother was known for having great artistic skills in both music and visual arts.

Albert trained as an architect and in 1902 he partnered with his brother, Julius. Julius was a civil engineer and developed a novel approach to reinforcing concrete. Steel rod running the length of the concrete would separate from the concrete under any flex. Julius' solution was to encase bars at a 45° angle thus distributing the load more evenly, reducing flex in the final product. This was the secret to Albert Kahn's success especially in Detroit.

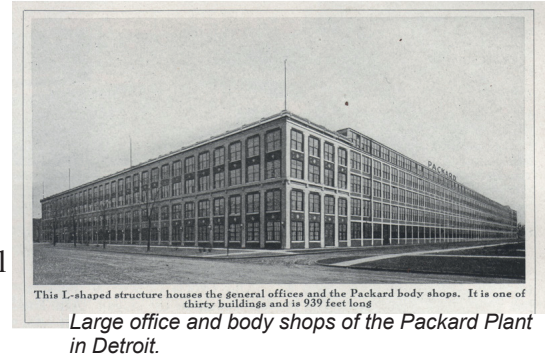

No. 786,602. PATENTED AUG. 16, 1908.
 J. KAHN.
 CONCRETE AND METAL CONSTRUCTION.
 APPLICATION FILED DEC. 11, 1906.
 4 SHEETS-SHEET 1.
 NO MODEL.

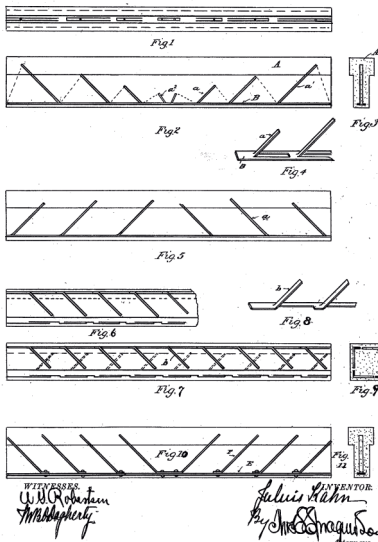

Patent for Julius Kahn's reinforced concrete. This allowed his brother Albert Kahn to span large distances and create large open spaces in concrete structures.

factories for Chrysler, Chalmers, Checkers and Studebaker as well as the old headquarters for Consumers Energy in Jackson, MI, the old Flint Journal building and the old Post Office in Battle Creek, MI. He also designed airplane hangars for Langley Air Force Base in Virginia.

Albert Kahn died at the age of 73 in 1942. Most of his working papers are held by the Bentley History Library at the University of Michigan or the Albert Kahn Library Collection at Lawrence Technological University. Many of his personal letters and such are held by the Smithsonian Institute at their Archives of American Art. 



Left: The General Motors building in Detroit served as GM's headquarters from 1923 - 2001 when they were moved to the Renaissance Center.

Right: The rooftop of General Motor's Research Laboratory was a favorite place of GM designers to take factory photos. This 1931 Sedan Delivery sits atop the Research laboratory and the GM Building is seen in the background.



Albert Kahn is credited with designing about 600 buildings in Michigan. Many of which were for the automotive industry. He designed many of Ford's plants, most notably, the gigantic River Rouge Complex, which when completed in 1928 became the largest manufacturing facility in the world passing Flint's Buick City.

Albert designed GM's most notable building of the 19th century in the General Motor's Building (now known as Cadillac Place) and the General Motor's Research Laboratory (Argonaut Building) which is right across the road from the GM Building. He also designed the Willow Run Bomber Plant which Ford built during WW2. GM eventually bought the building from Kaiser-Frazer and it became Willow Run Transmission from 1953 to 2010.

Other notable buildings designed by Albert Kahn include the Fisher Building (built by the Fisher family with money from selling Fisher Body), The Edsel and Eleanor Ford House in Grosse Pointe Woods, MI, The Packard Automotive plant, opened in 1903 as the "most modern automobile factory in the world". Sadly, demolition on the long-dilapidated Packard Plant began in October 2022, after numerous failed attempts to preserve it. Kahn also designed



above: Advertisement for Kahn System of Buildings.

2023 Lower Michigan Region, VCCA Dust-Off Tour

May 20, 2023

Tour Overview:

This year's dust-off Tour is a one day tour visiting three attractions in Montrose/Birch Run area. \$10 Tour Donation covers admission to the Telephone Museum

Telephone Museum

We will meet at 8:30 AM (Breakfast, optional)

Junction of Hope Restaurant

4136 Peet Rd

(Route M57, 6 miles East of Chesaning)

departing at 9:30 AM.

First Stop: 10:00 AM

Montrose Antique Telephone Museum

144 Hickory Street, Montrose

Second Stop: Lunch 12:00

Leo's Coney Island,

8645 Main St, Birch Run, MI 48415

Third Stop: _1:30 PM Hugh Periard Farm and Antique Truck & Farm Equipment Collection,
2717 E. Birch Run Road

Fourth Stop: TBD

Maps and Directions will be supplied
on the day of the tour.

The Following Members signed up for the 2022 Mothball and are automatically signed up for the
Dust-Off:

Tim Reinke, Robin Reinke, John McMullen, Michael Lauth, Bruce & Mary Granger, Rod & Denice
Thomas, Dave & Phyllis Rickabus, Dennis & Bonnie Reinke, Brian Granger

Questions: Contact Bill Anderson

248-881-6510

old50grit@comcast.com

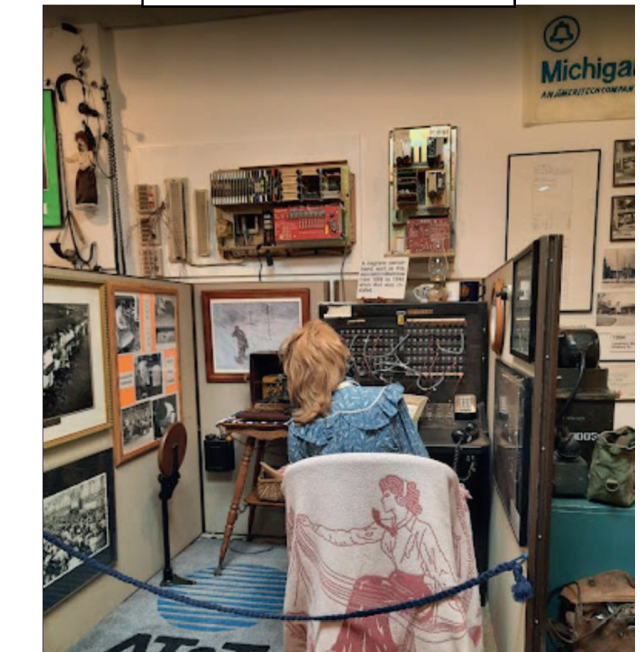

Signup form can be found on
pg. 7 of this newsletter

The Lower Michigan Region Proudly Hosts:



July 19-23
2023

The 60th
VCCA
Central Meet

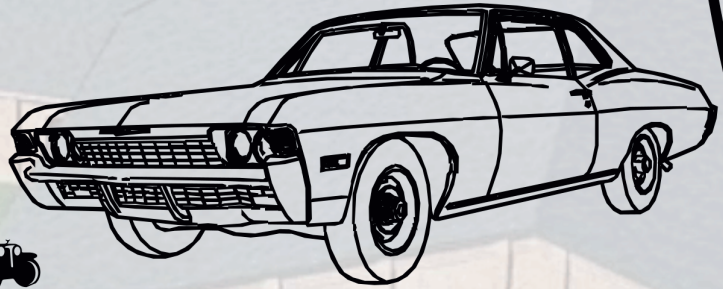

GILMORE
CAR MUSEUM

★
Kalamazoo, MI

VCCA members can get
more information, and
register at:
vccacentralmeet.org

Lower Michigan Region, VCCA 2023 Calendar

March

20 Eastside A's MARC Swap Meet Macomb MI

April

16 Monroe Swap and Sell Monroe MI
16 LMR-VCCA Meeting @ Junction Resturant Layton Corners MI
1pm Board, 2pm General Membership

May

6 GLR – VMCCA Swap meet Fowlerville MI
20-21 LMR-VCCA Dustoff Tour – Location and Specifics TBD

June

10 BWR-AACA Car Show – Chevrolet Feature for 2023 Marysville MI
24-25 Sloan AutoFair Flint MI
LMR Membership Meeting – 1pm

July

6-8 Iola WI Swap Meet Iola WI
19-23 VCCA 60th Central Meet – LMR Host Region Kalamazoo MI
29 LMR Summer Picnic – Location & Specifics TBD

August

5 KAARC Red Barn Spectacular – Gilmore Car Museum Hickory Corner MI
19 Back to the Bricks Flint MI

September

17 Sloan Museum Golden Memories Flint MI
LMR Membership Meeting – 1pm

October

2-6 AACA -Eastern Fall Meet Hershey Pa
13-14 LMR-VCCA Dustoff Tour – Location and Specifics TBD
22 LMR-VCCA Meeting @ Junction Resturant Layton Corners MI
1pm Board, 2pm General Membership

November

Banquet will be held in April 2024

For Sale: 1928 National Landau coupe. Frame off restoration of high quality blue-black leather interior & white walls. call for more info. asking \$18,000. Mike McFarland: 810-790-1812



From Behind the Steering Wheel

with Brian Granger

Br-r-r-r-r ! It's Cold / Snowy outside. I want warm weather, again. I Hope all is well with everyone. Let me and/or a Board Member know of any new changes you want to share with the Club. We would love to hear from you.

Tim and Pat Mehl, myself ,and others on the 60th Anniversary Central Meet Committee have been working hard, this winter, planning the event. They will post more information in the upcoming newsletters and on line.



There are no Federal Monday Holidays in March - no three day weekends. (We do have: 3/15 - Ides of March, 3/17 - St. Patrick's Day, 3/20 - 1st day of Spring.) Mark your calendars.

Happy Birthday to those March babies who have traveled around the sun again and Happy Anniversary to those couples who tied the knot in March.

I Hope to see many of you at our 1st meeting of the year on April 16, 2023, at 2 p.m., Junction of Hope Resturant, Layton Corners, MI.

GM in the News

On Wednesday February 22, 2023, General Motors announced a 2 week production halt at their Fort Wayne Indiana Truck plant starting March 27th.

General Motors says the shutdown is in order to "maintain optimal inventory levels." GM is targeting about 60 days of inventory at dealerships. In mid-2019, inventory levels were between 70 - 90 days. right now, Silverado 1500 inventory is more than 100 days.

GM claims full-size pickup demand has remained steady while production has increased in the past few months.

There is no plan to shut down Flint Assembly which makes Silverado 2500 and larger trucks.

source: The Detroit News

Happy Birthday!

- | | |
|-------------------|---------------------|
| 1 Jill Anderson | 18 Theresa Maveal |
| 2 Marth Bamfield | 19 Mary Samulski |
| 3 Jim Schott | 20 Mable Beam |
| 4 Matt Dickinson | 22 Gary Mehl |
| 5 Darrell Hammond | 22 Victor Pitcavage |
| 10 Pamela Nagy | 24 Diane Latora |
| 14 Bill Anderson | 24 Marge Henige |
| 15 Mike McFarland | 26 Bob Beam |
| 16 Cathy Sweet | 27 Mary Jo Klock |
| 17 Bob Gardner | 29 William Bissell |
| 17 Jo Carpenter | |

Happy Anniversary!

- Mike McFarland & Mary Samulski
March 4, 2000
- Bill & Sue Weinberg
March 26, 1955

2023 Board of Directors

Director	Brian Granger	Grangerb59@yahoo.com	(810) 348 - 5198
Asst. Director	Bill Anderson	old50grit@gmail.com	
Secretary	Tim Mehl	TLMehl54@hotmail.com	
Treasurer	Pat Mehl	Jakobs.grama@gmail.com	

Members-At-Large

Bruce Granger	Brucedgranger@yahoo.com
Bill Jusela	wjusela@comcast.net
Robin Reinke	(989) 513-0590
Denice Thomas	Denicet10345@yahoo.com

Ex-Officio	Vacant	
Membership	Bill Anderson	old50grit@gmail.com
ChatterEditor	Tim Reinke	treinke@gmail.com (989) 513-5129
Sunshine	Denice Thomas	Denicet10345@yahoo.com
Historian	BruceGranger	Brucedgranger@yahoo.com
	Brian Granger	GrangerB59@yahoo.com

The purpose of the VCCA is to promote interest in the preservation and restoration of vintage Chevrolet manufactured vehicles and GMC manufactured trucks. Ownership of a vintage Chevrolet or GMC is not a prerequisite for membership. LMR region dues are \$20 per year. To become a member, an applicant must be a National VCCA member in good standing. National dues are \$40 yearly.

2023 Lower Michigan Region, VCCA Dust-Off Tour

May 20, 2023

=====

REGISTRATION FORM

=====

Name: _____

Address: _____

Phone: _____

Additional Participants:

Name: _____

Name: _____

Name: _____

Emergency Contact: _____

Contact Phone: _____

Tour Donation: \$10/car

Checks Payable to: **Lower Michigan Region, VCCA**

Note: A donation to the Telephone Museum will be made.

Send this information to:

Bill Anderson

3301 Saddle Ridge, Highland, MI 48357

Cell: 248-881-6510

Email: old50grit@comcast.net.

Thank you to the following sponsor of the
LMR Chevy Chatter

www.LMRVCCA.org

*Follow the VCCA on Instagram @VCCA_Official
and visit the VCCA facebook page often!!*



Printmill
printing | graphics

4001 Portage Street

Kalamazoo, MI 49001

Phone: 269-382-0428

www.printmill.com

Richmond, MI 48062
29900 33 Mile Rd
Chevy Chatter Editor